

① South Wall

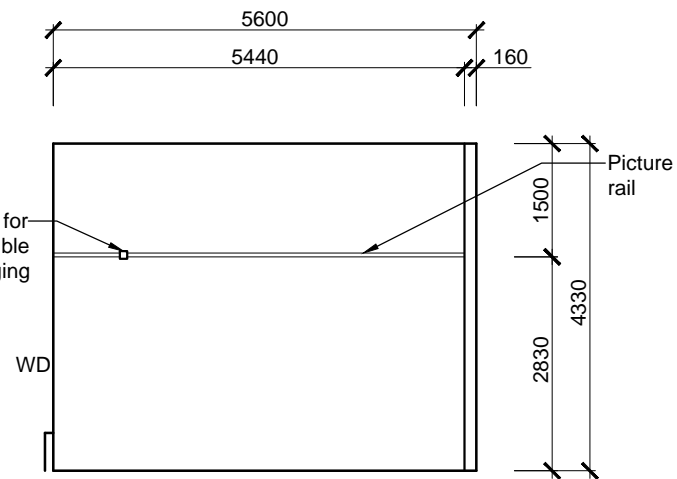

② West Wall

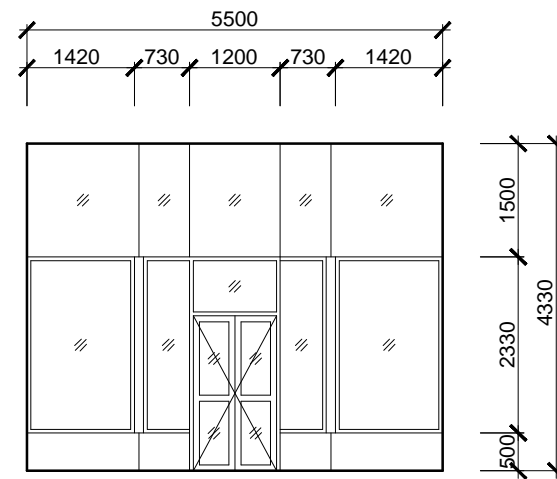

③ North Wall

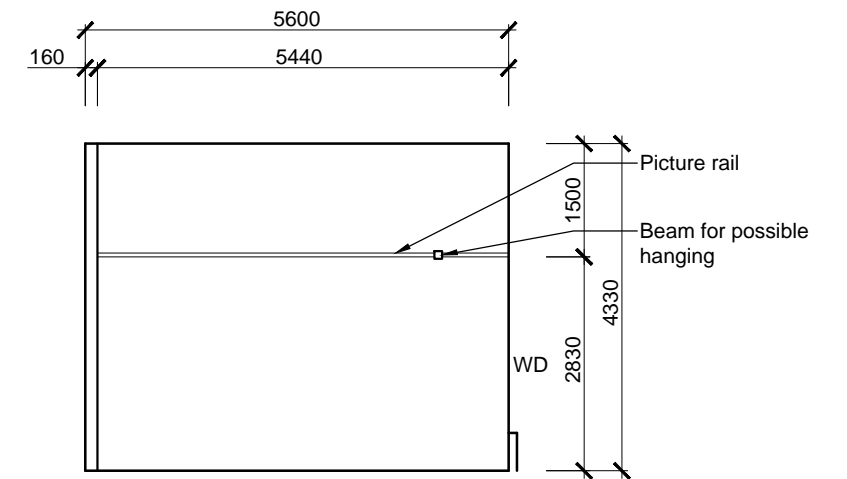

④ East Wall

Shopfront Internal Elevation

SCALE 1: 100 @ A3

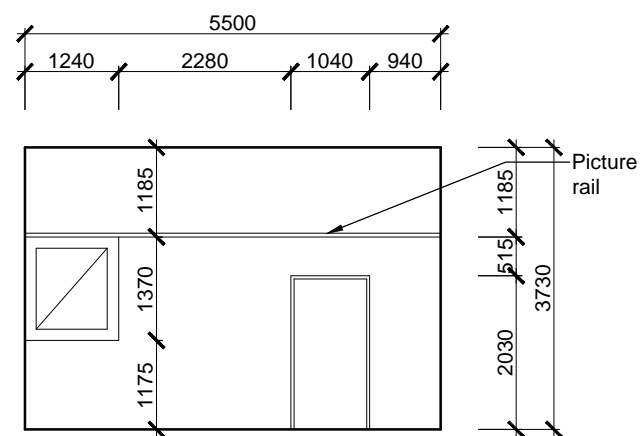

① South Wall

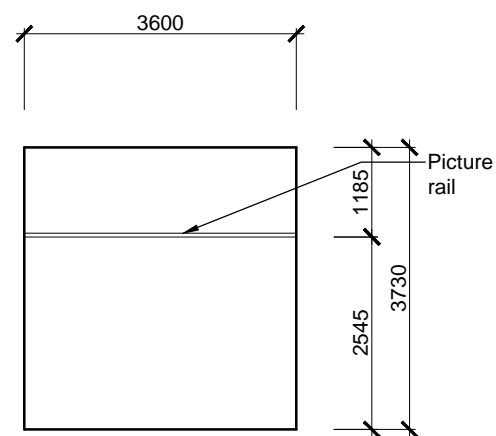

② West Wall

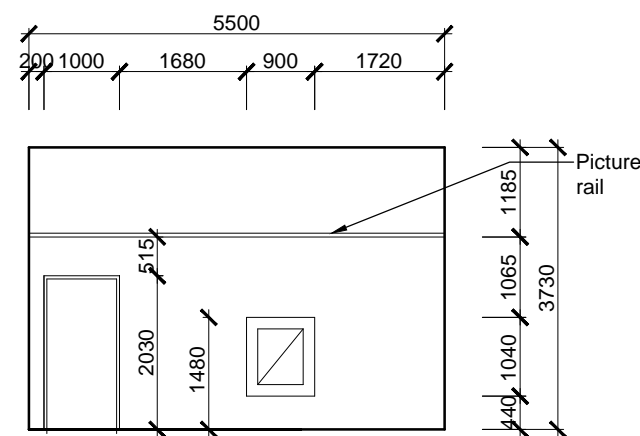

③ North Wall

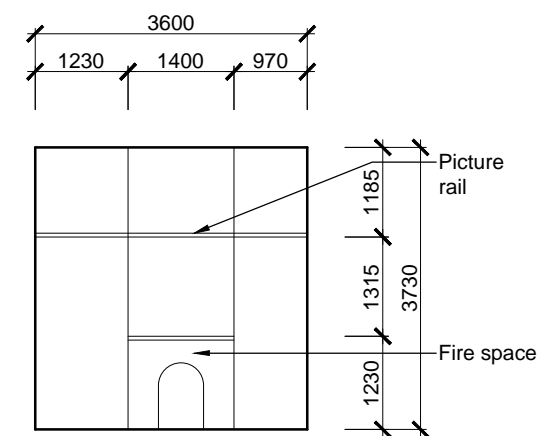

④ East Wall

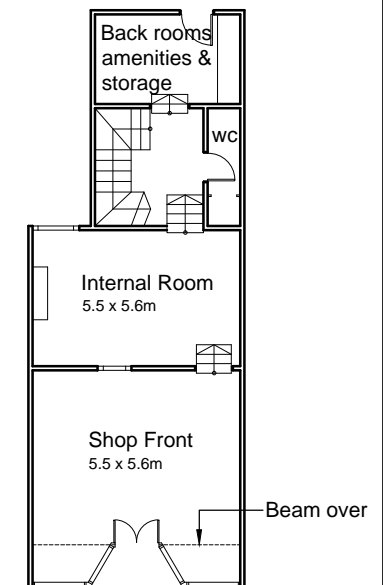

Key Map

Internal Room Internal Elevation

SCALE 1: 100 @ A3

CARROLL AND CARROLL
ARCHITECTS
398 BRONTE RD, WAVERLEY, 2024
Tel / Fax 02 9387 1045
Email carrollandcarrollarchitects@hotmail.com

The Shop Gallery
112 Glebe Point Road
Glebe, NSW

The Shop Gallery Internal Elevations

SCALE
1: 100 @ A3

DATE
20 January 2017

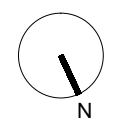

REVISION

DRAWING
NO.